

LogiLink®



Electric Dual Motor Sit-Stand Desk Frame

Art. No.: EO0001
EO0001G
EO0001W

Perfect sit-stand desk frame for office, school and home. Through digital control panel to adjust and save your desired height.

Features:

- » Digital LED memory controller for customizable settings to your desired height
- » 2 motors offer heavier lifting ability and increased stability
- » 3 programmable memory presets save your desired height
- » Time reminder for regular movement
- » Collision avoidance system safeguards against accidents and injuries
- » Motors are thermal and overload protected for safety and longevity
- » Switched mode power supply for energy and power efficiency
- » Adjustable width fits a variety of desktop shapes and sizes

Art-No.	Color	EAN Code
EO0001	Black	4052792047646
EO0001G	Gray	4052792051742
EO0001W	White	4052792061307



3 column stages
offer more
adjustability.



Cable management keeps
everything organized.



Adjustable feet level and
adapt to most floor
surface.



RoHS
compliant



*The specifications and pictures are subject to change without prior notice.
*All trade names referenced are the registered trademarks of their respective owners.

Made in China

Best Connectivity



Best Connectivity

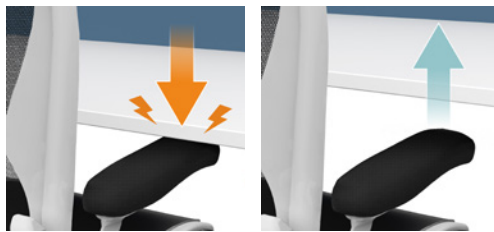

Safety Collision Avoidance System

If the desk hits an object, it will move in the opposite direction upward (downward) for about 3cm.

- 1. Memory
- 2. Screen Lock
- 3. Standby
- Up
- 3 Programmable Memory Preset
- 1. Down
- 2. Rest
- Current Height
- 1. Time Reminder
- 2. Switch between "cm" and "inch"



Effortlessly switch between sitting and standing.

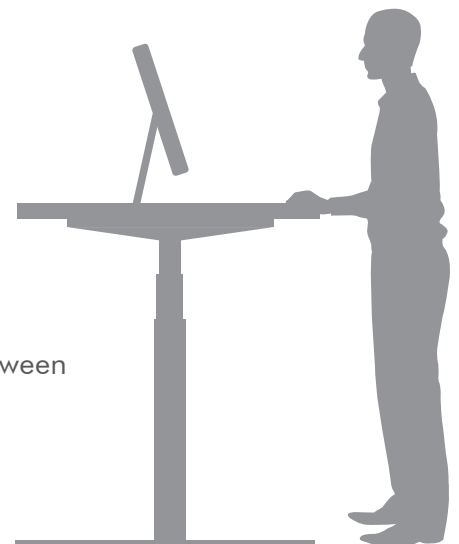

RoHS compliant



*The specifications and pictures are subject to change without prior notice.
*All trade names referenced are the registered trademarks of their respective owners.

LogiLink®



Electric Dual Motor Sit-Stand Desk Frame

Art. No.: EO0001
EO0001G
EO0001W

Specification:

Function	Electric Sit-Stand Desk Frame
Motor Quantity	2
Material	Steel
Height Range	620-1280mm (24.4"-50.4")
Width Range	1000-1700mm (39.4"-66.9")
Column Segments	3
Column Size	40 x 80 / 46 x 86 / 52.6 x 92.6mm
Product Dimension	1000 x 700 x 620mm (39.4" x 27.6" x 24.4")
Suggest Tabletop Size	1100-2200 x 700-1000mm (43.3"-86.6" x 27.6"-39.4")
IP Grade	IP20
Operating Temperature	-5°C~+40°C
Weight Capacity Range	100kg (220lbs)
Max. Speed	38mm/s
Power Input	100-240V

Package Contents:

- » 1 x Dual Motor Sit-Stand Desk Frame
- » 1 x Digital Control Panel
- » 1 x Screw Pack
- » 1 x User Manual

Package Information:

- » Packing Dimension: 110.5 x 29.5 x 22mm
- » Packing Weight: 37.14kg
- » Carton Dimension: 110.5 x 29.5 x 22mm
- » Carton Q'ty: 1pcs
- » Carton Weight: 37.14kg

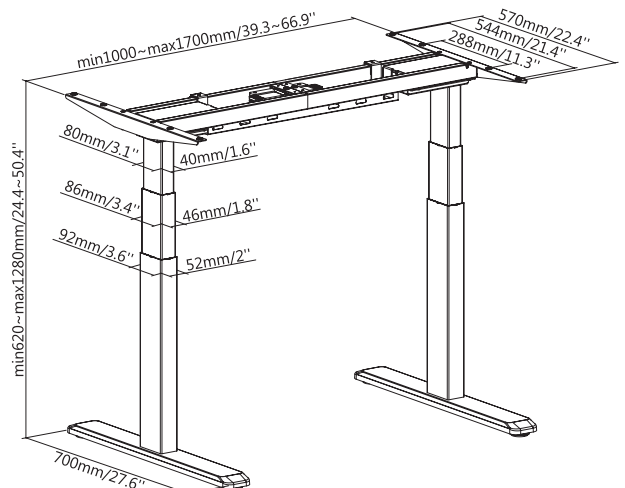

RoHS
compliant



*The specifications and pictures are subject to change without prior notice.
*All trade names referenced are the registered trademarks of their respective owners.

Made in China