

multipower - mp®

RECHARGEABLE SEALED LEAD ACID BATTERY

SPECIFICATION



MPC50-12I

Nominal Voltage(V) 12V

Nominal Capacity

20 hour rate	(2.50A to 10.50V)	50.00Ah
10 hour rate	(4.75A to 10.50V)	47.50Ah
5 hour rate	(8.50A to 10.20V)	42.50Ah
1 C	(50A to 9.60V)	28.33Ah
3 C	(150A to 9.60V)	20.00Ah

Weight Approx. 15.1kg (33.2Lbs.)

Internal Resistance (at 1KHz) Approx. 5 mΩ

Maximum Discharge Current for

5 seconds: 600A

Charging Methods at 25°C (77°F)

Cycle use:	
Charging Voltage	14.7 to 14.8V
Coefficient -5.0mV/°C/cell	
Maximum Charging Current:	15A
Standby use:	
Float Charging Voltage	13.5 to 13.8V
Coefficient -3.0mV/°C/cell	

Operating Temperature Range

Charge	-15°C (5°F) to 40°C (104°F)
Discharge	-15°C (5°F) to 50°C (122°F)
Storage	-15°C (5°F) to 40°C (104°F)

Charge Retention (shelf life) at 20°C (68°F)

1 month	98%
3 month	94%
6 month	85%

Case Material ABS UL94 HB

Terminal F8

Description of torque value of hard ware for the terminals:

Recommended torque value	M6: 7 N·m (71 kgf·cm)
Maximum allowable torque value	M6: 10 N·m (102 kgf·cm)

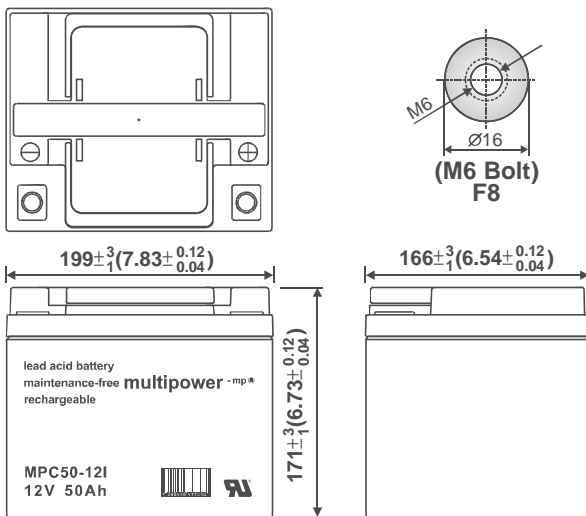

(V) FOR 12V BATTERY Discharge Time VS. Discharge Current (25°C)

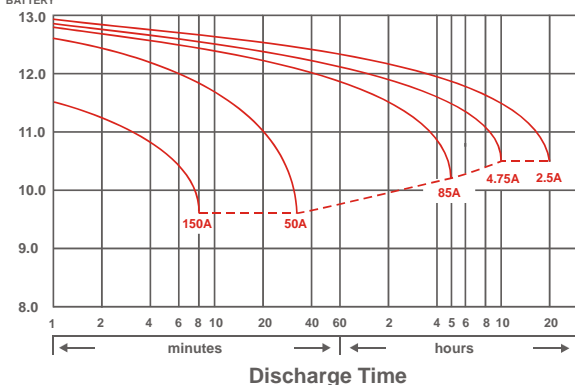

CHARACTERISTIC & PERFORMANCE DATA

Effect of Temperature on Capacity 25°C (77°F)

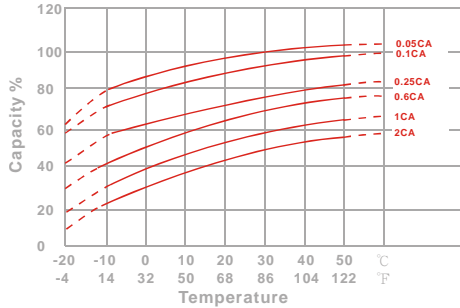

Capacity Retention Characteristic

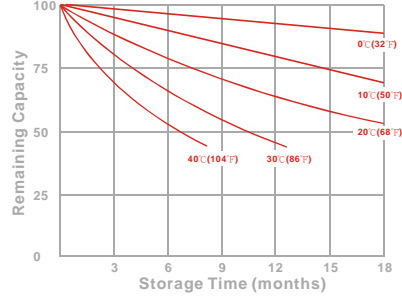

Trickle (or float) Service Life

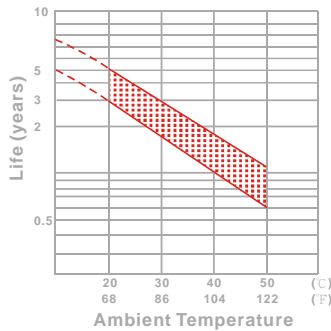

Cycle Service Life

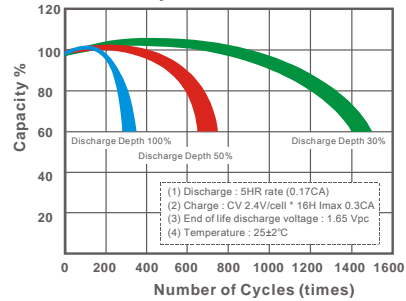

- PERFORMANCE DATA

Discharge Rates in Watts per Cell to Various End Voltages at 25°C (77°F)

End Voltage		1.85V	1.80V	1.75V	1.70V	1.67V	1.65V	1.60V
Time								
5	min	235	282	316	338	343	348	354
10	min	168	199	218	228	232	237	241
15	min	124	143	157	163	166	169	171
30	min	76.4	88.0	95.2	98.3	99.5	101	102
60	min	52.6	55.4	57.0	58.3	58.8	59.5	59.9
120	min	29.2	32.0	33.3	34.5	34.8	35.3	35.8
180	min	20.8	22.7	23.8	24.7	25.0	25.3	25.7
240	min	17.2	18.3	19.0	19.7	19.8	20.2	20.5
300	min	15.9	16.6	17.0	17.3	17.5	17.7	17.8
600	min	8.62	9.10	9.38	9.57	9.62	9.68	9.77
1200	min	4.58	4.87	5.05	5.17	5.20	5.25	5.30

- Discharge Rates in Amperes per Battery to Various End Voltages at 25°C (77°F)

End Voltage		1.85V	1.80V	1.75V	1.70V	1.67V	1.65V	1.60V
Time								
5	min	136	163	181	195	202	206	210
10	min	86.7	104	115	123	125	128	131
15	min	76.2	82.8	85.8	88.4	89.1	90.0	91.0
30	min	44.5	49.7	51.7	53.3	53.8	54.4	55.1
60	min	25.5	28.2	29.3	30.0	30.2	30.5	30.8
120	min	15.1	16.2	16.8	17.3	17.5	17.7	17.9
180	min	11.0	11.7	12.1	12.4	12.5	12.6	12.7
240	min	8.96	9.44	9.70	9.89	9.96	10.1	10.2
300	min	7.85	8.26	8.50	8.67	8.73	8.80	8.87
600	min	4.41	4.65	4.76	4.82	4.84	4.87	4.91
1200	min	2.32	2.44	2.50	2.55	2.57	2.59	2.61

All data on the spec. sheet is an average value:

The tolerance range : $X < 6\text{min}$ (+15%~-15%), $6\text{min} \leq X < 10\text{min}$ (+12%~-12%), $10\text{min} \leq X < 60\text{min}$ (+8%~-8%), $X \geq 60\text{min}$ (+5%~-5%)